

TxBLOCK-USB Transmitter

TEMPERATURE TRANSMITTER – OPERATING MANUAL – V1.0x D – 0555 0033



INTRODUCTION

The TxBLOCK-USB is a 4-20 mA 2-wire temperature transmitter for head mount, powered by the current loop. Its configuration is accomplished by connecting the transmitter to a PC USB port without the need of any dedicated interface. The configuration does not require that the transmitter be powered.

The output current is linearized and adjusted in function of the input sensor type and range configured.

SPECIFICATIONS

Sensor input: User defined. The supported sensors are listed in Table 1, along with their maximum ranges.

Thermocouples: Types J, K, R, S, T, N and E, according to IEC 60584 (ITS-90). Impedance $\gg 1 \text{ M}\Omega$

Pt100: Type 3-wire, Excitation 0.8 mA, $\alpha = 0.00385$, according IEC 60751 (ITS-90).
For 2-wire sensors, tie terminals 3 and 4 together.

Pt1000: Type 3-wire, Excitation 0.17 mA, $\alpha = 0.00385$, according IEC 60751 (ITS-90).
For 2-wire sensors, tie terminals 3 and 4 together.

NTC R_{25°C}: 10 k Ω $\pm 1 \%$, B_{25/85} = 3435

Voltage: 0 to 50 mVdc. Impedance $\gg 1 \text{ M}\Omega$

Sensor type	Max. Measurement Range	Min. Measurement Range
Voltage	0 to 50 mV	5 mV
Thermocouple K	-150 to 1370 °C	100 °C
Thermocouple J	-100 to 760 °C	100 °C
Thermocouple R	-50 to 1760 °C	400 °C
Thermocouple S	-50 to 1760 °C	400 °C
Thermocouple T	-160 to 400 °C	100 °C
Thermocouple N	-270 to 1300 °C	100 °C
Thermocouple E	-90 to 720 °C	100 °C
Thermocouple B	500 to 1820 °C	400 °C
Pt100	-200 to 650 °C	40 °C
Pt1000	-200 to 650 °C	40 °C
NTC	-30 to 120 °C	40 °C

Table 1 – Sensors accepted by the transmitter

Switch-on delay: < 2.5 s. The accuracy is only guaranteed after 15 min.

Calibration error: < 0.11 % (RTD and mV) and < 0.15 % (TC).

Terms of reference: ambient: 25 °C; voltage: 24 Vdc, load: 250 ; Ω settling time: 10 minutes.

Temperature Effect: < $\pm 0.16 \%$ / 25 °C

Cold junction compensation: < ± 1 °C.

Response time: typical 1.6 s.

Maximum voltage allowed at input terminals no sensor: 3 V.

RTD current: 800 μ A.

RTD cable resistance effect: 0.005 °C /

Maximum allowable cable resistance for RTD: 25 Ω .

Sensor Type	Typical Accuracy	Minimum Accuracy
Pt100 / Pt1000 (-150 a 400 °C)	0,10 %	0,12 %
Pt100 / Pt1000 (-200 a 650 °C)	0,13 %	0,19 %
mV, K, J, T, E, N, R, S, B	0,1 %	0,15 %
NTC	0,3 °C	0,7 °C

Table 2 – Calibration error, percentage of the full measurement range.

Power supply influence: 0.006 % / V typical (percentage of the full measure range).

Output: 4-20 mA or 20-4 mA current, 2-wired; linear in relation to the temperature measurement by the selected sensor.

Output Resolution: 2 μ A.

Power supply: 10 to 35 Vdc, across the transmitter;

Maximum load (RL): $RL \text{ (max.)} = (V_{dc} - 10) / 0.02 \text{ [}\Omega\text{]}$
Where: Vdc= Power supply voltage (10-35 Vdc)

Operating Temperature: -40 to 85 °C

Humidity: 0 to 90 % RH

Electromagnetic Compatibility: EN 61326-1:2006

No electrical isolation between input and output..

Internal protection against polarity inversion.

Cold junction compensation for thermocouples.

Dimensions: 43.5 mm (diameter) x 20.5 mm (height)

Connection Wire Cross Section: 0.14 a 1.5 mm²

Screw Tightening: 0.8 Nm.

Housing: ABS UL94-HB.

CONFIGURATION

When the transmitter is used with the factory setting, no further action is required and the transmitter is ready to be installed. Changes to the configuration are possible through the **TxConfig II** software, provided free of charge.

A **TxBLOCK-USB Setup Kit** consisting of the Txconfig II software and USB cable can be purchased from the manufacturer or any authorized distributor. The Txconfig II software is continuously updated and new versions can be downloaded at no charge from the manufacturer's website. To install, execute the **TxConfigIISetup.exe** file and follow the instructions.

TxBLOCK-USB Transmitter

TEMPERATURE TRANSMITTER – OPERATING MANUAL – V1.0x D – 0555 0033

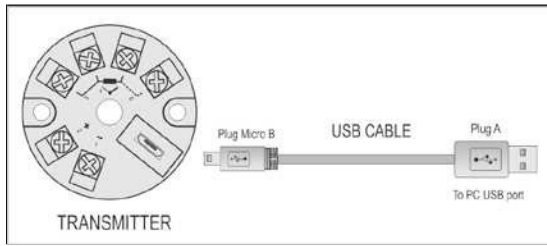

Fig. 1 – USB cable connection

During the setup, the transmitter is powered by the USB, not requiring an external power supply.

The transmitter setup can also be made by connecting it to the loop, using the *loop* power supply. There is no electrical insulation between the transmitter and the communication port (interface), therefore, it is not recommended to configure it with the sensor inlet connected to the process. See Fig. 2.

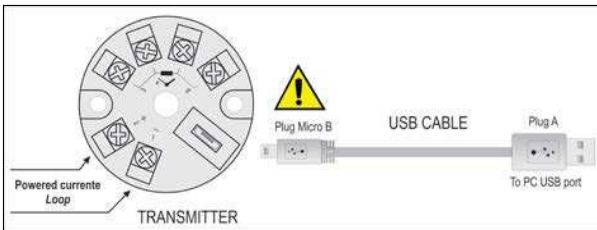

Fig. 2 – USB cable connections – Loop powered

After these connections, the user must run the *TxConfig II* software and, if necessary, consult the *Help* topic to help using the software.



The USB communication port (interface) of the TxBLOCK-USB is not electrically insulated from the transmitter's input.

SOFTWARE CONFIGURATION:

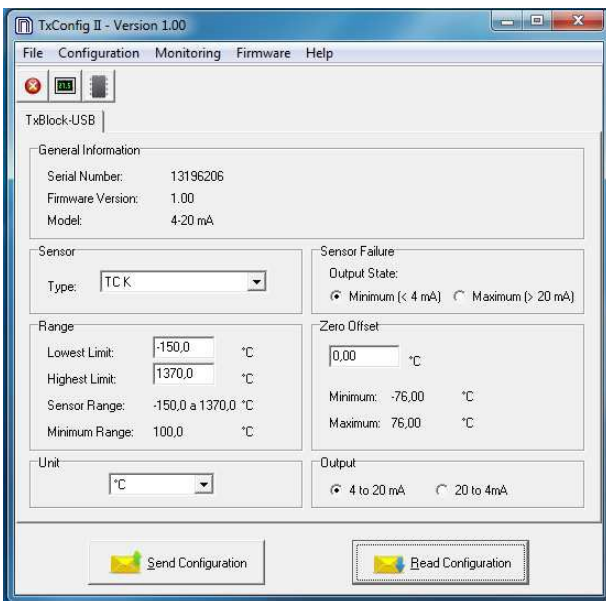

Fig. 3 – TxConfig II software main screen

The fields in the screen mean:

- General Information:** This field shows information that identifies the transmitter. This information should be sent to the manufacturer when requesting technical assistance.
- Sensor:** Select the type of sensor to be used. See Table 1.
- Measuring Range:** Sets the measurement range of the transmitter.
Lower Range Limit: equivalent temperature for a current of 4 mA.
Upper Range Limit: equivalent temperature for a current of 20 mA.

Sensor Range

The values chosen cannot exceed the **range of sensor** shown in this field. See Table 1 of this manual.

Minimum Range

Do not set a lower band (span) than the **Minimum Range** indicated further down in the same field. See Table 1 of this manual.

- Sensor Failure:** It establishes the output behavior when the transmitter indicates a failure:

Minimum: Output current goes to < 3.8 mA (down-scale), typically used for refrigeration.

Maximum: Output current goes to > 20.5 mA (up-scale), typically used for heating.

- Zero Correction:** It corrects small deviations presented in the transmitter output, for example, when the sensor is replaced.
- Send Configuration:** It applies the new setup. Once sent, the setup will be immediately adopted by the transmitter.
- Read Configuration:** Reads the current setup in the transmitter connected. The screen now presents the current setup that may be changed by the user.

FACTORY SETTING:

- Sensor: Pt100 3-wire, range 0 to 100 °C
- Sensor failure: upscale (maximum).
- 0 °C zero correction.
- Unit: °C;
- Output: 4 to 20 mA.

Upon purchase order, the user can define a specific setup.

MECHANICAL INSTALLATION

The TxBLOCK-USB transmitter is suitable to be installed in heads. Vibrations, moisture and extreme temperatures, electro-magnetic interference, high voltage and other interferences can permanently damage the unit, and could cause error in the measured value.

DIMENSIONS:

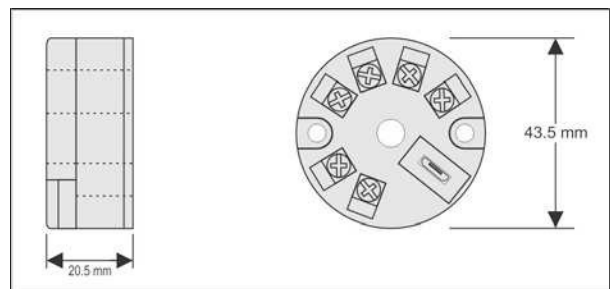

Fig. 4 – Transmitter dimensions

TxBLOCK-USB Transmitter

TEMPERATURE TRANSMITTER – OPERATING MANUAL – V1.0x D – 0555 0033

ELEKTRICAL INSTALLATION

- Polyamide enclosure.
- Section of the cable used: 0.14 to 1.5 mm²
- Recommended torque in the terminal: 0.8 Nm.

RECOMMENDATIONS FOR INSTALLATION

- Sensor signals conductors must go through the plant system separate from power leads (loop), if possible in grounded conduits.
- The instruments must be powered by the instrumentation power supply circuit.
- In control and monitoring applications it is essential to consider what can happen when any part of the system fails.
- It is recommended the use suppressors in contact coils, solenoids and any inductive load.

ELECTRICAL CONNECTIONS

The figures below show the electrical connections required. The terminals 3, 4, 5 and 6 are dedicated to the sensor connection. **LOAD** represents the 4-20 mA current measuring device (indicator, controller, recorder, etc.).

PT100 2-WIRES

Note: At the Pt100 2-wires the terminals 3 and 4 must be interconnected, according to the figure below.

The Pt100 wire length **should be less than 30 cm** to maintain the measurement error within specifications (electrical resistance).

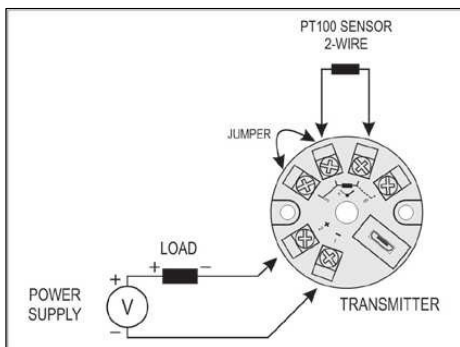

Fig. 5 – Transmitter electrical connections (Pt100 2-wires)

PT100 3-WIRES

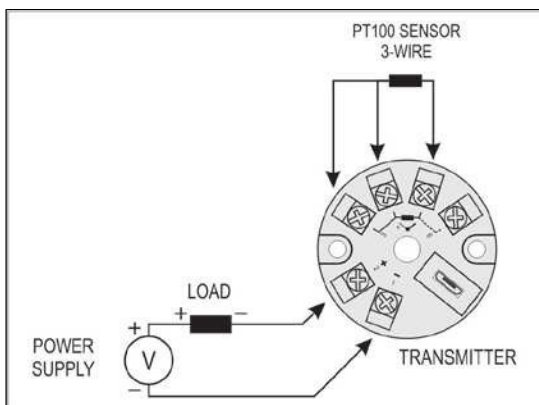

Fig. 6 – Transmitter electrical connections (Pt100 3-wires)

PT100 4-WIRES

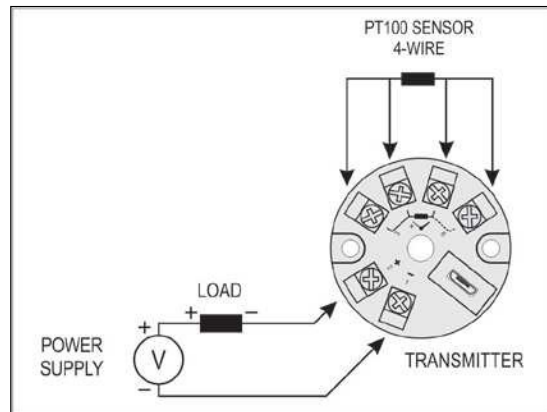

Fig. 7 – Transmitter electrical connections (Pt100 4-wires)

Pt1000 3 wires / Pt100 3- and 4 wires: For appropriate cable resistance compensation they should be equal for all legs. Maximum wire resistance is 25 Ω per wire leg. Usage of a 3 or 4 wire with conductors of equal length an gauge is recommended.

THERMOCOUPLES

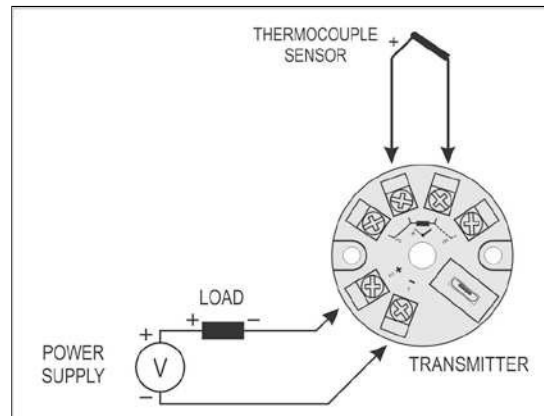

Fig. 8 – Transmitter electrical connections (Thermocouple)

VOLTAGE (0-50 mV)

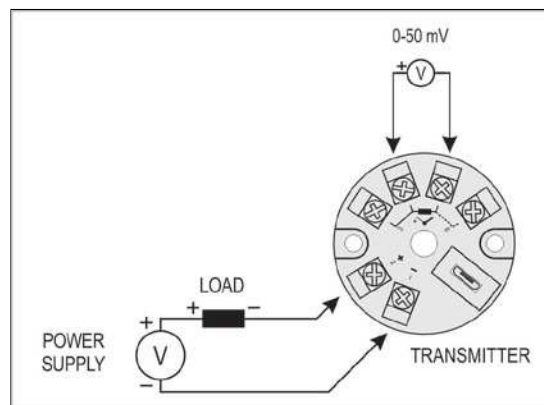

Fig. 9 – Transmitter electrical connections (0-50 mV)

TxBlock-USB Transmitter

TEMPERATURE TRANSMITTER – OPERATING MANUAL – V1.0x D – 0555 0033

OPERATION

The sensor offset can be changed through the *TxConfig II* software. The USB cable may be connected to the transmitter without causing any measurement errors. See item *Zero Correction* in the chapter **CONFIGURATION** of this manual.

The user must choose the most suitable sensor and range to the process. The chosen range must not exceed the maximum range of measurement defined for the sensor and should not be smaller than the minimum range for the same sensor.

It is important to note that the transmitter accuracy is based on the maximum range of the sensor used, even when a narrower range is programmed. Example:

- The sensor Pt100 has a max. range of -200 to +650 °C and accuracy of 0.12 %, thus we will have an error up to 1.02 °C (0.12 % of 850 °C).
- This error may be present even when a narrower range is configured for the sensor. (For example: 0 to 100 °C.)

Note: When measurements are made at the transmitter, see if the Pt100 excitation current required by the calibrator is compatible with the Pt100 excitation current used in the transmitter: 0.8 mA

SAFETY INFORMATION

Any control system design should take into account that any part of the system has the potential to fail. This product is not a protection or safety device and its alarms are not intended to protect against product failures. Independent safety devices should always be provided if personnel or property is at risk.

Product performance and specifications may be affected by its environment and installation. It is the responsibility of the user to ensure proper grounding, shielding, cable routing and electrical noise filtering, in accordance with local regulations, EMC standards and good installation practices.

SUPPORT AND MAINTENANCE

This product contains no serviceable parts inside. Contact your distributor in case you need authorized service.